

## SLEEVE CUFF FOR A JACKET

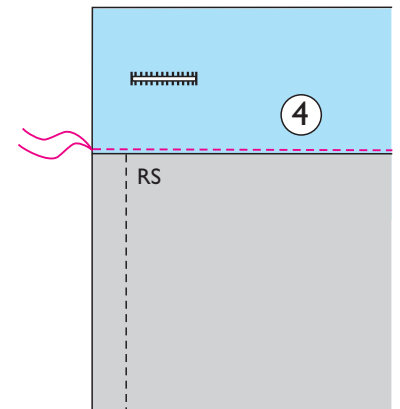
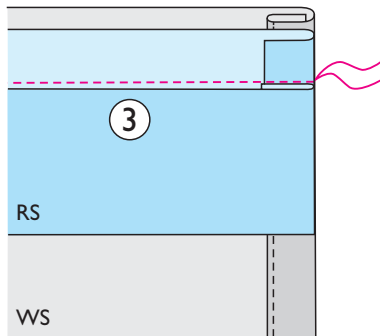
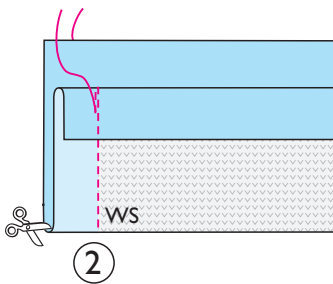
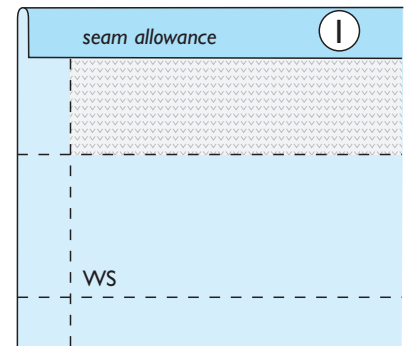
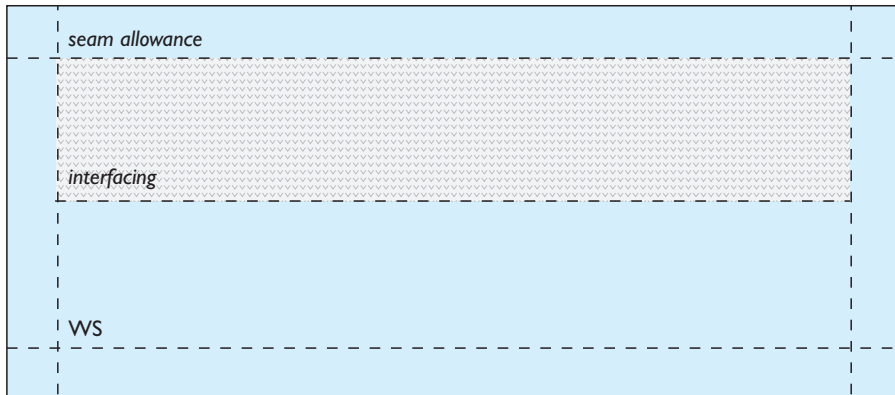

**Stabilizing:** Fuse interfacing to outer halves of sleeve cuffs.

1. Turn and press seam allowance at attachment edge of outer half (= interfaced half) of sleeve cuff to wrong side.

2. Fold cuff in half right sides together and stitch its side edges. Clip through seam allowance along cuff foldline at corners and turn cuff right side out.

3. Pin and stitch right side of inner cuff half (= non-interfaced half) to wrong side of bottom edge of sleeve.

4. Fold cuff right way up. Pin open edge of cuff to right side of sleeve-edge seam and stitch it in place close to edge.

# OTTOBRE